

50 MAN THROW OVER BOARD SELF RIGHTING LIFERAFT ROUND CONTAINER SOLAS A & B PACK

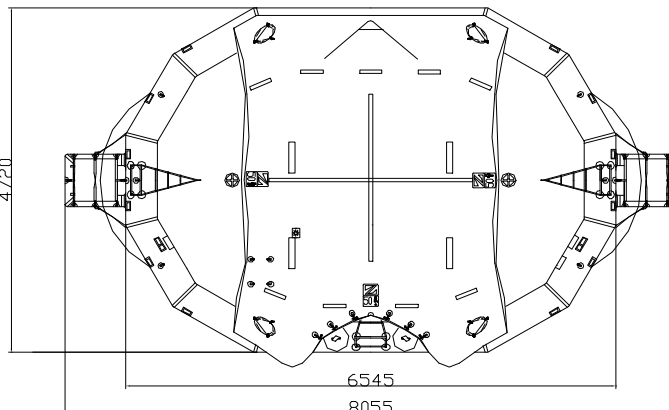
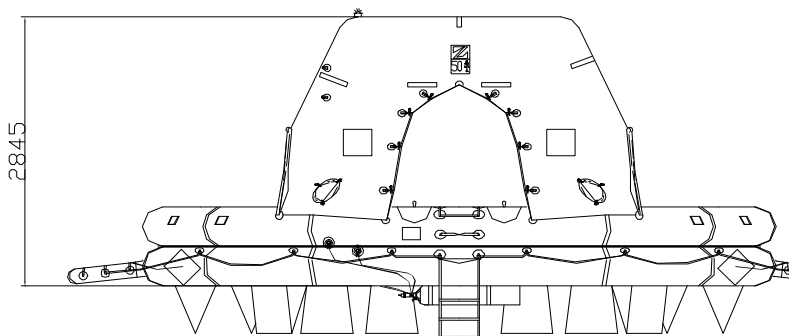
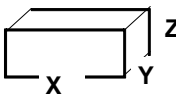

50 MAN	A PACK			B PACK		
Container	N20			N18		
Dimensions	X: 1560 mm	Y: 952 mm	Z: 960 mm	X: 1560 mm	Y: 852 mm	Z: 835 mm
	X: 5' 1,42"	Y: 3' 1,49"	Z: 3' 1,8"	X: 5' 1,42"	Y: 2' 9,55"	Z: 2' 8,88"
Liferaft Net Weight	370 kg / 816 pounds			246 kg / 543 pounds		
Max. height stowage	25 m / 83'			27 m / 89'		
Painter line length	35 m / 115'					
Inflation Cylinder	2 x 27 liter					

 Crate	X: 1640 mm	Y: 1050 mm	Z: 1150 mm	X: 1640 mm	Y: 940 mm	Z: 1010 mm
	X: 5' 4,57"	Y: 3' 5,34"	Z: 3' 9,28"	X: 5' 4,57"	Y: 3' 1,01"	Z: 3' 3,77"
	439 kg / 968 pounds			301 kg / 664 pounds		
	1,981 m3 / 69,93 cubic foot			1,558 m3 / 54,98 cubic foot		

Towing force	2 knots	3 knots
Without sea anchor	155 daN	210 daN
With sea anchor	170 daN	225 daN

Approvals: **EC (MED) – USCG – BV**

50 TO SR 21092011 KLT.doc Issue : 4 Date: 21/09/2011

Dimensions and weight +/- 5%
 SURVITEC SAS reserves the right to change specification without notice.
 For installation, add minimum +10mm for clearance to dimensions of the container.