

## 25 PERSON DAVIT LAUNCHED LIFERAFT

### ROUND CONTAINER - SOLAS A & B PACK

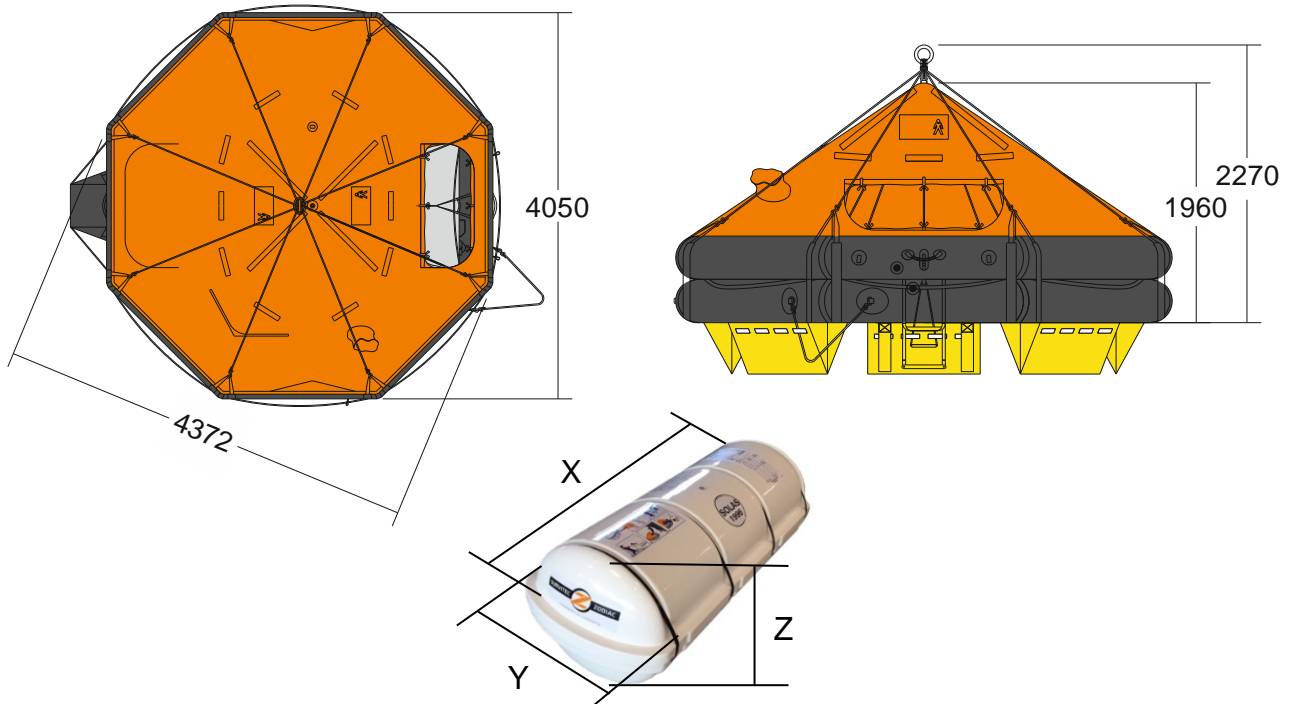

25 DL	A PACK	B PACK
Container	<b>RND MK14 S17</b>	<b>RND MK14 S17</b>
<i>Dimensions</i>	X: 1308mm    Y: 713mm    Z: 685mm X: 4'3,50"    Y: 2'5"    Z: 2'3"	X: 1308mm    Y: 713mm    Z: 685mm X: 4'3,50"    Y: 2'5"    Z: 2'3"
Liferaft net weight	185kg / 408 lbs	135kg / 298 lbs
Height of stowage	46m / 151' (maximum)	
Painter line length	56m / 184'	
Crate <i>Dimensions &amp; weight</i>	X: 1350mm    Y: 840mm    Z: 900mm X: 4'5,15"    Y: 2'9,08"    Z: 2'11,44" 205kg / 452 lbs	X: 1350mm    Y: 840mm    Z: 900mm X: 4'5,15"    Y: 2'9,08"    Z: 2'11,44" 155kg / 342 lbs
Towing force	<b>2 knots</b> 130 daN / 292 lbf	<b>3 knots</b> 259 daN / 582 lbf

Approvals:	<b>EC - USCG - TC</b>
------------	-----------------------

25 DL ROUND 22112016 KLT.doc	Issue: 1	Date: 22/11/2016
------------------------------	----------	------------------

Dimensions and weight +/- 5%  
 SURVITEC SAS reserves the right to change specification without notice.  
 For installation, add minimum +10mm for clearance to dimensions of the container.