

MARINE EVACUATION SYSTEM (MES) 100 MAN THROW OVER BOARD SELF RIGHTING VENTURI LIFERAFT ASSOCIATED WITH SMALL INFLATABLE SLIDE (SIS)

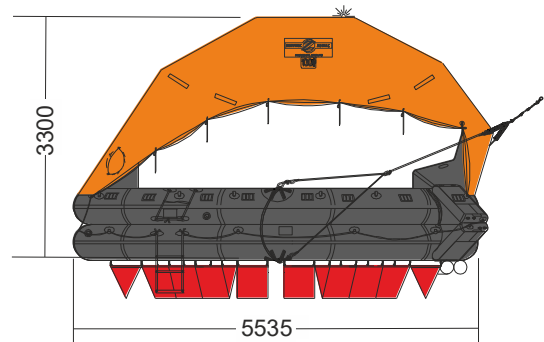
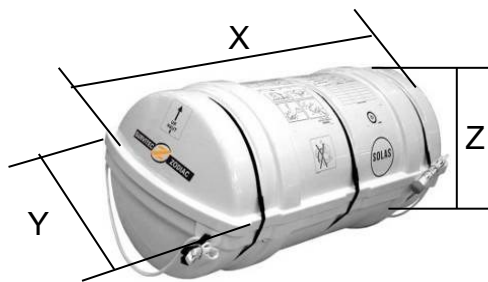
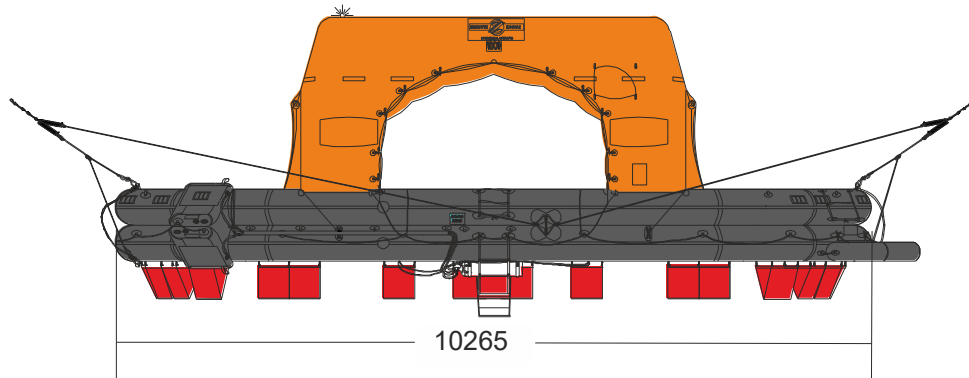
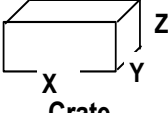

100 MAN	A PACK			B PACK		
Container	N27			N26		
Dimensions	X: 2100 mm X: 6' 10,68"	Y: 1070 mm Y: 3' 6,13"	Z: 1038 mm Z: 3' 4,87"	X: 2000 mm X: 6' 6,75"	Y: 968 mm Y: 3' 2,12"	Z: 930 mm Z: 3' 0,62"
Liferaft Net Weight	545 kg / 1202 pounds			410 kg / 904 pounds		
Max. height stowage	20 m / 66'			20 m / 66'		
Painter line length	35 m / 115'					
Inflation Cylinder	3 x 27 liter + 1 x 2,83 liter					

 Crate	X: 2100 mm X: 6' 8,71"	Y: 1150 mm Y: 3' 9,28"	Z: 1188 mm Z: 3' 11,25"	X: 2000 mm X: 6' 8,71"	Y: 1150 mm Y: 3' 9,28"	Z: 1080 mm Z: 3' 11,25"
	610 kg / 1345 pounds			454 kg / 1001 pounds		
	2,87 m3 / 101,31 cubic foot			2,484 m3 / 87,72 cubic foot		

Towing force	2 knots	3 knots
Without sea anchor	220 daN	433 daN
With sea anchor	265 daN	518 daN

100 TO SR V MES SIS.doc	Issue: 7	Date: 09/10/2019
-------------------------	----------	------------------

Dimensions and weight +/- 5%
SURVITEC SAS reserves the right to change specification without notice.
For installation, add minimum +10mm for clearance to dimensions of the container.

SIS (SMALL INFLATABLE SLIDE)



Slide in valise

SIS	1,70 m			2,20 m		
Valise						
Dimensions	X:670mm	Y:300mm	Z:260mm	X:720mm	Y:425mm	Z:295mm
	X:2' 2,38"	Y:11,82"	Z:10,24"	X:2' 4,35"	Y:1' 4,74"	Z:11,62"
Slide net weight	15 kg / 34 pounds			19 kg / 42 pounds		
Max. evacuation height	1,70 m			2,20 m		
Firing line length	1,50 m			1,50 m		
Inflation cylinder	1 x 2,83 litres			1 x 4 litres		

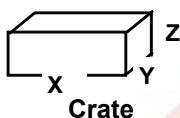

Crate

X:830mm	Y:540mm	Z:330mm	X:830mm	Y:540mm	Z:330mm
X:2' 8,68"	Y:1' 9,26"	Z:1' 1"	X:2' 8,68"	Y:1' 9,26"	Z:1' 1"
17,6 kg / 39 pounds			21,6 kg / 48 pounds		
0,148 m ³ / 5,23 cubic foot			0,148 m ³ / 5,23 cubic foot		

SIS	2,70 m			3,20 m		
Valise						
Dimensions	X:720mm	Y:450mm	Z:295mm	X:800mm	Y:450mm	Z:295mm
	X:2' 4,35"	Y:1' 5,72"	Z:11,62"	X:2' 7,5"	Y:1' 5,72"	Z:11,62"
Slide net weight	27 kg / 60 pounds			28,5 kg / 63 pounds		
Max. evacuation height	2,70 m			3,20 m		
Firing line length	1,50 m			1,50 m		
Inflation cylinder	1 x 6 litres			1 x 6,7 litres		

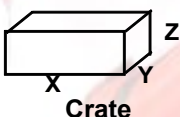

Crate

X:830mm	Y:540mm	Z:330mm	X:830mm	Y:540mm	Z:330mm
X:2' 8,68"	Y:1' 9,26"	Z:1' 1"	X:2' 8,68"	Y:1' 9,26"	Z:1' 1"
29,6 kg / 66 pounds			31,1 kg / 69 pounds		
0,148 m ³ / 5,23 cubic foot			0,148 m ³ / 5,23 cubic foot		

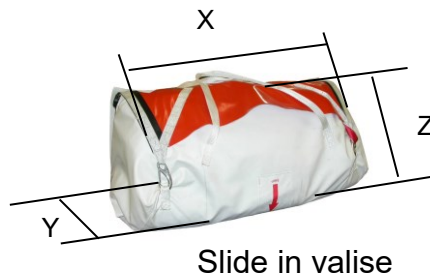

SIS	3,80 M		
	Valise		
Dimensions	X: 820 mm	Y: 450 mm	Z: 350 mm
	X: 2' 8,29"	Y: 1' 5,72"	Z: 1' 1,78"
Slide net weight	37 kg / 82 pounds		
Max. evacuation height	3,8 m / 13'		
Firing line length	1,5 m / 5'		
Inflation cylinder	1 x 10 liter		

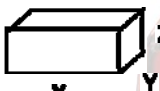
 <p style="text-align: center;">Crate</p>	X: 920 mm	Y: 560 mm	Z: 370 mm
	X: 3' 0,23"	Y: 1' 10,05"	Z: 1' 2,57"
	40 kg / 89 pounds		
	0,191 m3 / 6,74 cubic foot		

Approvals:	EC
-------------------	-----------

100 TO SR V MES SIS.doc	Issue: 7	Date: 09/10/2019
-------------------------	----------	------------------

Dimensions and weight +/- 5%
 SURVITEC SAS reserves the right to change specification without notice.
 For installation, add minimum +10mm for clearance to dimensions of the container.