

ORIL 50 MAN OPEN REVERSIBLE INFLATABLE LIFERAFT ROUND CONTAINER

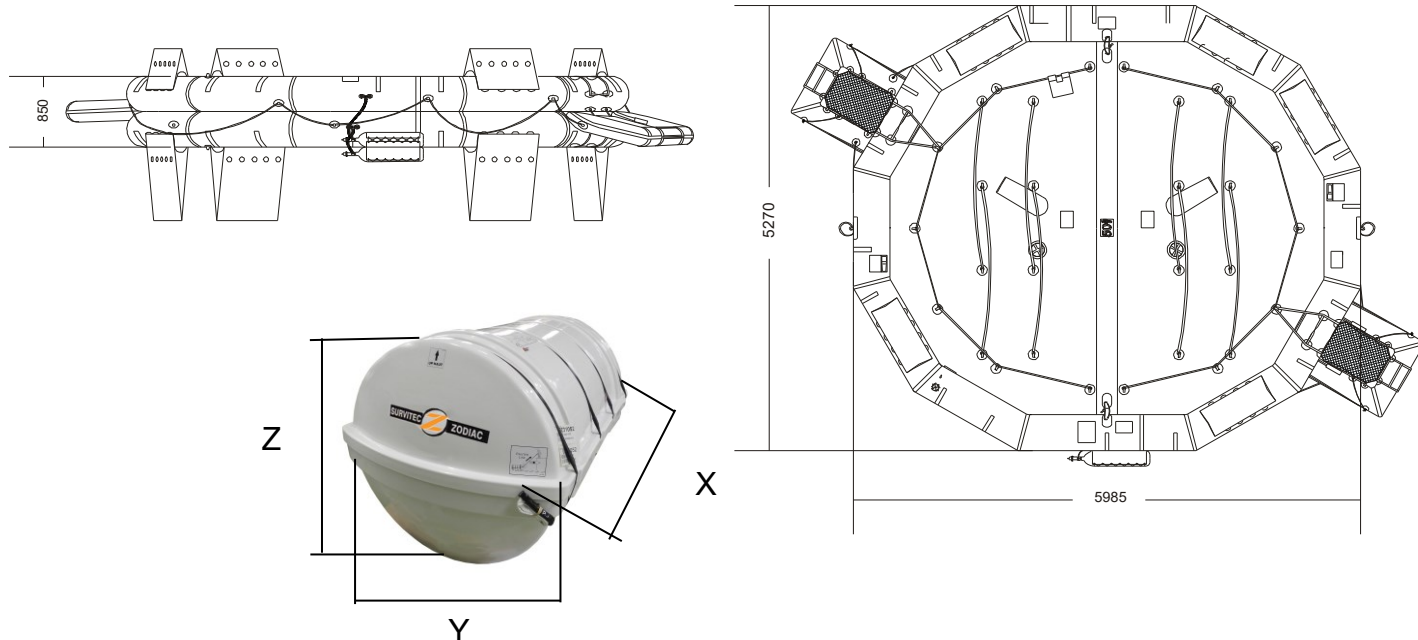
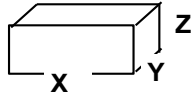

| 50 MAN | HSC PACK / SMA PACK / RINA PACK | | |
|---------------------|---------------------------------|------------|-------------|
| Container | N15 | | |
| Dimensions | X: 1275 mm | Y: 800 mm | Z: 740 mm |
| | X: 4' 2,2" | Y: 2' 7,5" | Z: 2' 5,14" |
| Liferaft Net Weight | 170 kg / 375 pounds | | |
| Max. height stowage | 18 m / 60' | | |
| Painter line length | 18 m / 60' | | |
| Bowsing line length | 10 m / 33' | | |
| Inflation Cylinder | 2 x 20 liter | | |

| | | | |
|---|---------------------|-------------|--------------|
|  Crate | X: 1350 mm | Y: 840 mm | Z: 900 mm |
| | X: 4' 5,15" | Y: 2' 9,08" | Z: 2' 11,44" |
| | 190 kg / 419 pounds | | |
| 1,021 m3 / 36,04 cubic foot | | | |

| Towing force | 2 knots | 3 knots |
|---------------------|----------------|----------------|
| Without sea anchor | 120 daN | 195 daN |
| With sea anchor | 165 daN | 270 daN |

| | |
|-------------------|----------------------------|
| Approvals: | EC (MED) – BV – CRS |
|-------------------|----------------------------|

| | | |
|-----------------------|----------|------------------|
| ORIL 50 cont rond.doc | Issue: 6 | Date: 16/04/2019 |
|-----------------------|----------|------------------|

Dimensions and weight +/- 5%
 SURVITEC SAS reserves the right to change specification without notice.
 For installation, add minimum +10mm for clearance to dimensions of the container.