

16 PERSON DAVIT LAUNCHED LIFERAFT

ROUND CONTAINER - SOLAS A & B PACK

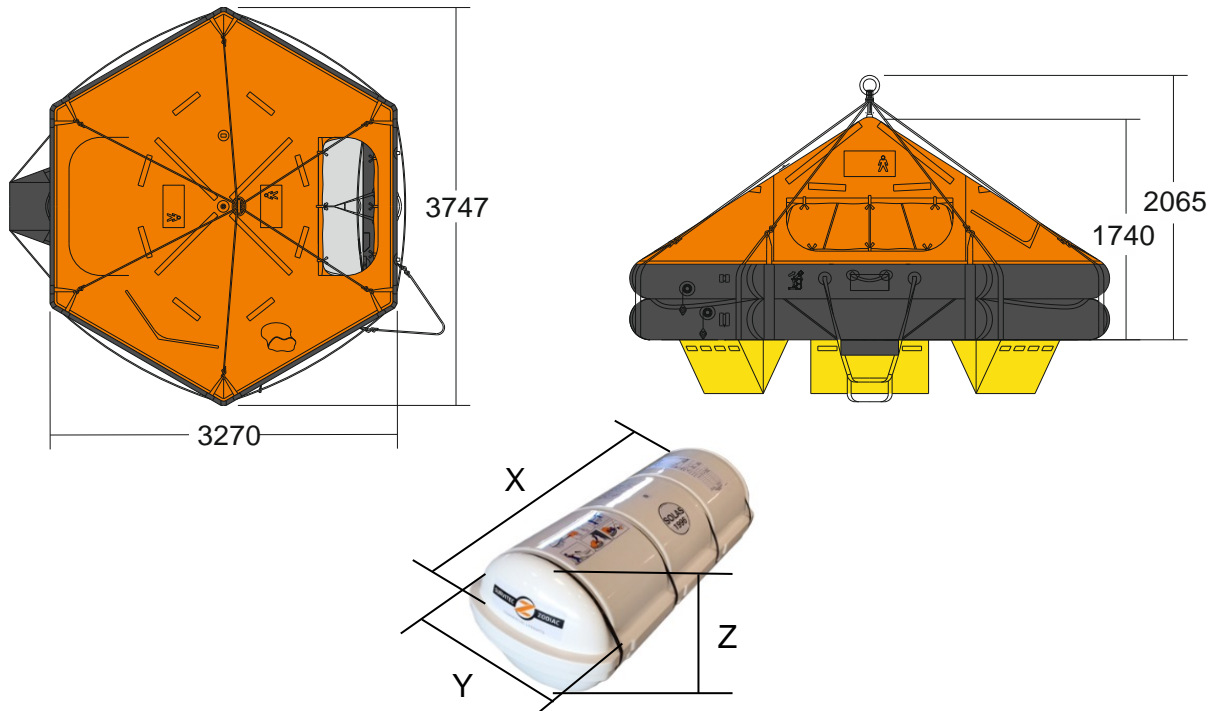

16 DL	A PACK	B PACK
Container	RND MK14 S17	RND MK14 S14
<i>Dimensions</i>	X: 1308mm Y: 713mm Z: 685mm X: 4'3,50" Y: 2'5" Z: 2'3"	X: 1156mm Y: 612mm Z: 584mm X: 3'9,50" Y: 2'1" Z: 1'11"
Liferaft net weight	141kg / 311 lbs	106kg / 234 lbs
Height of stowage	46m / 151'	36m / 118' (maximum)
Painter line length	56m / 184'	46m / 151'
Crate	X: 1350mm Y: 840mm Z: 900mm X: 4'5,15" Y: 2'9,08" Z: 2'11,44"	X: 1250mm Y: 600mm Z: 700mm X: 4'1,22" Y: 1'10,05" Z: 2'3,56"
<i>Dimensions & weight</i>	161kg / 355 lbs	121kg / 267 lbs
Towing force	2 knots 87 daN / 196 lbf	3 knots 206 daN / 463 lbf

Approvals:	EC - USCG - TC
------------	-----------------------

16 DL ROUND 22112016 KLT.doc	Issue: 1	Date: 22/11/2016
------------------------------	----------	------------------

Dimensions and weight +/- 5%
 SURVITEC SAS reserves the right to change specification without notice.
 For installation, add minimum +10mm for clearance to dimensions of the container.